

## CONTACT STRESSES AND FORMING LOAD IN UPSETTING OF PRISMATIC BILLETS BY V-SHAPE DIES

*Ivanišević Aljoša\*, Vilotić Dragiša, Plančak Miroslav, Kačmarčik Igor, Movrin Dejan  
Milutinović Mladomir, Skakun Plavka*

*Faculty of Technical Science – University of Novi Sad, Serbia*

### ABSTRACT

*Upsetting processes represent an elementary operation which is often integrated into complex technological processes of cold and hot bulk metal forming. These processes also play significant role in material formability analyses. For that reason it is important to know the stress-strain state and main parameters of the process. These parameters can be determined by different methods: pure theoretical, experimental and numerical method.*

*In this paper, process of upsetting of prismatic billet by V-shape dies has been analyzed theoretically and experimentally. Stress component were determined by using the method of solving approximate equilibrium equation, whereas forming load was obtained by integration of contact stresses and verified experimentally.*

**Key words:** *upsetting, V-shape die, theoretical solution, experiment*

### 1. INTRODUCTION

Processes of upsetting are the basic operations which investigations play a great role in designing of technology of bulk metal forming. Most often used dies for upsetting processes are flat plates, but also, various modes of upsetting of prismatic and cylindrical billets find their application in the analysis of materials formability. Upsetting with dies of various geometries is presented on Fig.1. and results are published in [1, 2, 3].

In paper [1] stress analysis for forming with cylindrical dies has been presented. The slab method was used to examine the variation of the stress state with the die radius and the interface friction. Upsetting of cylinder by conical and spherical dies is presented in [2, 3]. Given in [4] is the stress analysis of upsetting of strain-hardening material with curve dies. In paper [5] process of upsetting

---

\*Corresponding author's email: [aljosa@uns.ac.rs](mailto:aljosa@uns.ac.rs)

of cylinder by two cone-concave dies has been analyzed theoretically and experimentally in order to determine the influence of die geometry on main process parameters. In [6] theoretical and experimental investigation of rivet heading by spherical dies is presented. For theoretical analysis slab method was used. Analysis of upsetting of prismatic billet by cylindrical die using slab method and FEM is presented in paper [7].

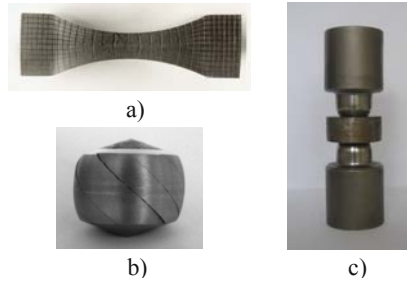

Fig.1. - Upsetting with dies of various geometries:  
a) cylindrical dies [1], b) conical dies [2], c) spherical dies [3]

In this paper results obtained by theoretical analysis and experiment in the case of upsetting of prismatic billet by V-shape dies are elaborated.

Experimental part of the paper was realized in the Laboratory for Technology of Plasticity at the Department of Production Engineering in Novi Sad. The upsetting of prismatic billets made from steel C45E was performed by V-shape dies on Sack und Kiesselbach hydraulic press of 6,3 MN rated force. Two series of billets with square section were used.

## 2. THEORETICAL ANALYSIS OF CONTACT STRESSES AND FORMING LOAD IN UPSETTING OF PRISMATIC BILLET BY V-SHAPE DIES

The scheme of upsetting of prismatic billet by V-shape dies is shown on Fig. 2. Determination of stress components has been accomplished by using the method of solving approximate equilibrium equation (slab method). In order to determine the stress state and forming load by upsetting of prismatic billet by V-shape dies, following assumptions have been made:

- During the deformation the plane strain state occurs
- All plane sections parallel to the axis of prismatic billet remain plane during deformation
- Tangential contact stress  $\tau_k$  is the result of friction on the contact surface of dies and billet and its proportion to normal contact stress  $\sigma_n$  and to friction coefficient  $\mu$  :

$$\tau_k = \mu \sigma_n \quad (1)$$

For theoretical analysis value of coefficient of friction  $\mu$  is 0,12 (lubrication with mineral oil). More about contact stresses and friction phenomenon can be found in [8, 9].

- For the assumed stress scheme presented on Fig.2, a Mises Yield criterion is:

$$\sigma_n - \sigma_x = 1,1K \quad (2)$$

- Yield stress K is constant

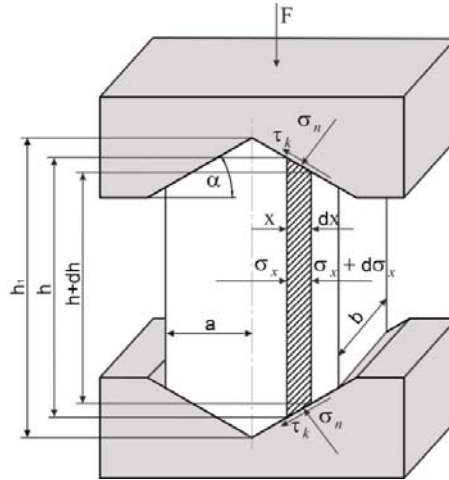

Fig. 2 – Stress scheme in upsetting of prismatic billet by V-shape dies

Based upon the Fig. 2 which shows the components of main stress, the differential equilibrium equation can be written in the form:

$$\sigma_x \cdot h \cdot b - (\sigma_x + d\sigma_x) \cdot (h + dh) \cdot b - 2 \cdot \sigma_n \cdot \sin \alpha \cdot \frac{dx}{\cos \alpha} \cdot b - 2 \cdot \tau_k \cdot \cos \alpha \cdot \frac{dx}{\cos \alpha} \cdot b = 0 \quad (3)$$

After transformation of (3), and with the assumption  $\tau_k = \mu \sigma_n$  ( $\mu$  -coefficient of friction), the following expression can be obtained:

$$\sigma_x \cdot dh + d\sigma_x \cdot h + 2 \cdot \sigma_n \cdot \operatorname{tg} \alpha \cdot dx + 2 \cdot \mu \cdot \sigma_n \cdot dx = 0 \quad (4)$$

By substituting in (4) the yield criterion of the form:

$$\sigma_n - \sigma_x = 1,1K \quad d\sigma_n = d\sigma_x \quad (5)$$

(where K – effective stress), the expression (4) becomes:

$$(\sigma_n - 1,1K) \cdot dh + d\sigma_n \cdot h + 2 \cdot \sigma_n \cdot \operatorname{tg} \alpha \cdot dx + 2 \cdot \mu \cdot \sigma_n \cdot dx = 0 \quad (6)$$

The relationship between ( $h$ ) and ( $x$ ) can be seen from Fig. 2, and it is:

$$h = h_1 - 2 \cdot \operatorname{tg} \alpha \cdot x \quad dh = -2 \cdot \operatorname{tg} \alpha \cdot dx \quad (7)$$

By substituting (7) in (6) the next equation is obtained:

$$(\sigma_n - 1,1K) \cdot (-2 \cdot \operatorname{tg} \alpha \cdot dx) + d\sigma_n \cdot (h_1 - 2 \cdot \operatorname{tg} \alpha \cdot x) + 2 \cdot \sigma_n \cdot \operatorname{tg} \alpha \cdot dx + 2 \cdot \mu \cdot \sigma_n \cdot dx = 0 \quad (8)$$

Further transformation of (8) gives:

$$\frac{-2 \cdot dx}{h_1 - 2 \cdot tg\alpha \cdot dx} = \frac{d\sigma_n}{1,1K \cdot tg\alpha + \mu \cdot \sigma_n} \quad (9)$$

By integrating (9), the following expression is obtained:

$$\frac{1}{tg\alpha} \ln(h_1 - 2 \cdot tg\alpha \cdot x) = \frac{1}{\mu} \ln(1,1K \cdot tg\alpha + \mu \cdot \sigma_n) + \ln C \quad (10)$$

Constant of integration C can be obtained using the boundary condition:

$$\text{For } x = a, \sigma_n \text{ becomes } \sigma_n = 1,1K \quad (11)$$

Then, the constant C is:

$$C = \frac{(h_1 - 2 \cdot tg\alpha \cdot a)^{\frac{1}{tg\alpha}}}{(1,1K \cdot tg\alpha + \mu \cdot 1,1K)^{\frac{1}{\mu}}} \quad (12)$$

With (12), the final equation for the normal contact stress is:

$$\sigma_n = \frac{1,1K}{\mu} \left( (tg\alpha - \mu) \cdot \left( \frac{h_1 - 2 \cdot tg\alpha \cdot x}{h_1 - 2 \cdot tg\alpha \cdot a} \right)^{\frac{\mu}{tg\alpha}} - tg\alpha \right) \quad (13)$$

Equation (13) presents the normal contact stress distribution in the proces of upsetting of prismatic billet by V-shape dies. The illustration of theoretical solutions of normal contact stresses (Fig 4. and Fig. 5) are given for the billets presented on Fig. 3.

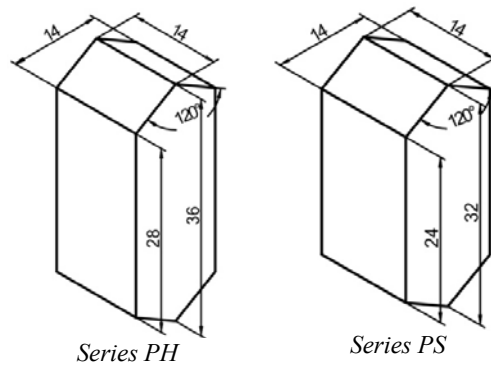

Fig.3 - Initial dimensions of the billets

For calculation of normal contact stress  $\sigma_n$  the flow curve for C45E steel, determined by Rastagaev's technique and approximated by the equation (14), was used:

$$K = 289,671 + 668,779\varphi_{ef}^{0,3184} \quad (14)$$

Effective plastic strain  $\varphi_{ef}$  was determined using equation (15).

$$\varphi_{ef} = \ln \frac{A}{A_0} \quad (15)$$

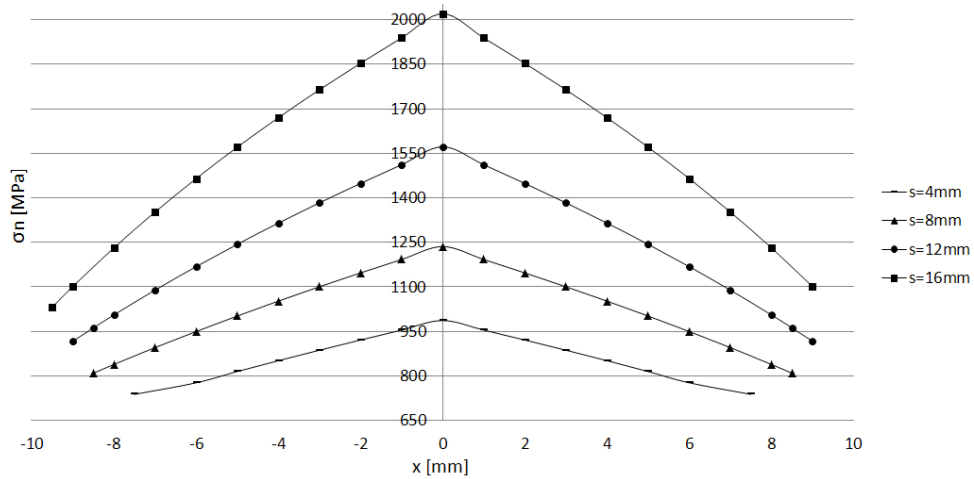

Fig. 4– Distribution of normal contact stress along x direction for PH series

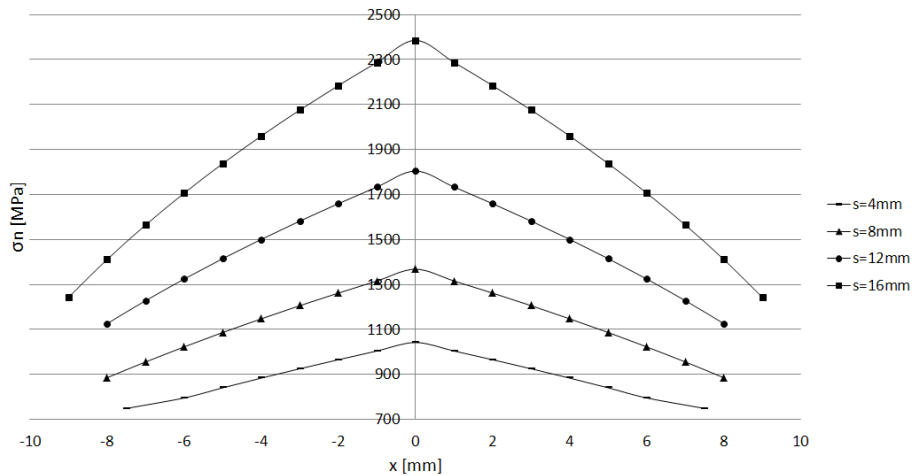

Fig. 5 – Distribution of normal contact stress along x direction for PS series

From Fig. 4 it can be concluded that maximum normal stress for series PH is approximately 2000MPa and that normal stress is achieved with die stroke of 16mm. For series PS maximum normal stress is approximately 2400MPa and also achieved with die stroke of 16mm, Fig. 5. It can be also seen that normal stresses for both series decrease with increasing of  $x$  coordinate.

By integration of contact stress at contact surface, the forming load is obtained:

$$F = \int_A (\sigma_n \cos \alpha - \tau_k \sin \alpha) dA \quad (16)$$

and

$$F = 2b \cdot (1 - \mu \cdot \operatorname{tg} \alpha) \int_0^a \sigma_n dx \quad (17)$$

By substituting (13) in (17) the next equation is obtained:

$$F = 2b \cdot (1 - \mu \cdot \operatorname{tg} \alpha) \cdot \frac{1,1K}{\mu} \int_0^a \left( \operatorname{tg} \mu + \mu \cdot \left( \frac{h_1 - 2 \cdot \operatorname{tg} \alpha \cdot x}{h_1 - 2 \cdot \operatorname{tg} \alpha \cdot a} \right)^{\frac{\mu}{\operatorname{tg} \alpha}} - \operatorname{tg} \alpha \right) dx \quad (18)$$

By integration of (18) forming load distribution in the process of upsetting of prismatic billet by V-shape dies is obtained:

$$F = 2b \cdot (1 - \mu \cdot \operatorname{tg} \alpha) \cdot \frac{1,1K}{\mu} \cdot \left( \frac{1}{2} (h_1 - \operatorname{tg} \alpha \cdot a) \cdot \left( \left( \frac{h_1}{h_1 - 2 \operatorname{tg} \alpha \cdot a} \right)^{\frac{\mu + \operatorname{tg} \alpha}{\operatorname{tg} \alpha}} - 1 \right) - \operatorname{tg} \alpha \cdot a \right) \quad (19)$$

Forming load – stroke diagrams for the billets given on Fig. 3, obtained theoretically and experimentally, are shown on Fig. 8.

### 3. EXPERIMENTAL TEST

Experimental determination of load-stroke diagram was conducted on Sack&Kiesselbach hydraulic press of 6,3MN. Beginning of the upsetting process is shown on Fig. 6.

The billets used in the experiment were made from C45E steel and its geometry is given on Fig.3.

The dies used in the experiment were polished and mineral oil was used as a lubricant.

Fig. 7 shows billets for both series before and after deformation. It can be seen from Fig.7. that the shape of the billets after deformation is similar for both series. Maximum stroke for both series was 16mm, and at the end of the process barreling of specimens occurred. Therefore, it can be concluded that the assumption, in which during the deformation process only plane strain state occurs, is not appropriate for billets dimension presented in this paper.

From the diagram on Fig.8a. it can be concluded that for series PH the forming load obtained by theory is higher than in the experiment during the entire process. From the process start to the die stroke of 10mm difference between theoretical and experimental loads is approximately 20% but after 10mm with an increase of the die stroke that difference increases and reaches 33%.

Fig.8b shows forming load diagram as a function of die stroke for series PS. It can be concluded that the forming load obtained by experiment is lower than theoretically calculated, during the entire process. After 2mm of the die stroke theoretical and experimental forming loads are almost equal but in the end of the process forming load obtained by theory is higher for approximately 21%.



Fig. 6 – Upsetting by V-shape dies

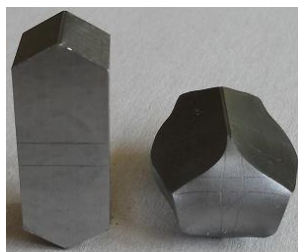

Series PH

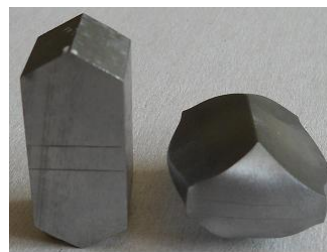

Series PS

Fig. 7 - Billets before and after deformation

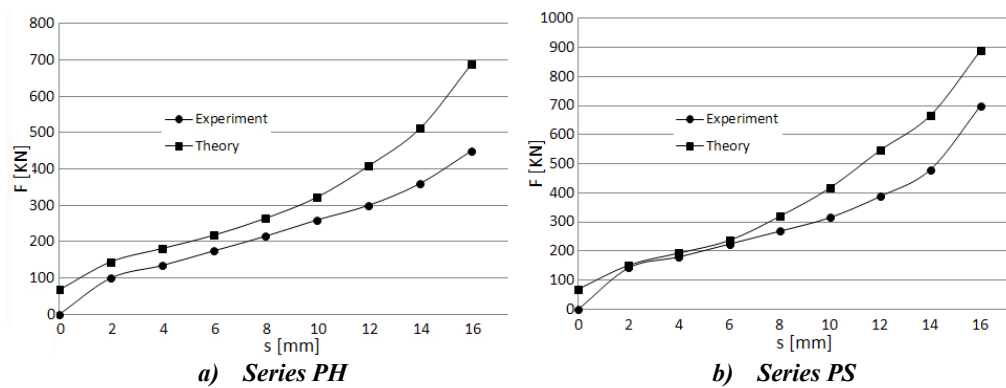

Fig. 8 – F-s diagram for billets series PH and PS

#### 4. CONCLUSION

Current paper elaborates theoretical and experimental investigation of free upsetting of prismatic C45E steel billets with V-shape dies. The aim was to determine contact stresses as well as forming load for two different billet series. Theoretical calculation of stresses and load was performed based upon slab method. Experiments were carried out in the Laboratory for Metal Forming, University Novi Sad, on 6300 KN hydraulic press.

Theoretical solution for contact stress shows that maximum stress occurs at the end of the upsetting process, in the middle of the billet. In case of shorter billets stress is higher and vice versa. Contact stress decreases with increasing distance from the central axis "x". Analytical value of forming load is obtained by integrating contact stress along the contact area. Forming loads obtained by experiment is in both cases lower than the load obtained theoretically. Relatively high discrepancy between theoretical and experimental results can be attributed to fact that in the theoretical analysis plane strain state was assumed, which might not describe the real conditions in proper way. In this regard further theoretical work is needed and planned.

#### ACKNOWLEDGEMENT

Results of investigation presented in this paper are part of the research realized in the framework of the project 114-451-1924/2011, financed by Provincial Secretariat for science and technological development AP Vojvodina.

#### REFERENCES

- [1] Vilotić, D., Shabaik, A.H. (1985) *Analisis of upsetting with profiling tools*, Journal of Engineering Materials and Technology, Vol. 107, pp. 261-264
- [2] Vilotić D., Plančak M., Grbić S., Alexandrov S., Chikanova N. (2003) *An approach to determining the workability diagram based on upsetting test*, Fatigue & Fracture of Engineering Materials & Structures, Vol.26, pp 305-310
- [3] Vilotić, D., Chikanova, S., Alexandrov, S. (1999) *Disc upsetting between spherical dies and its application to the determination of forming limit curves*, Journal of Strain Analysis, Vol. 34
- [4] Lin, S.Y. (2002) *Stress analysis of upsetting with concave curve dies*, Journal of Material Processing Technology, Vol. 213, pp 59-68
- [5] Vilotić D., Plančak M., Bramely, A., Osman, F. (2002) *Investigation of upsetting of cylinder by conical dies*, Journal for Technology of Plasticity, Vol. 27, No 1-2, pp 18-26
- [6] Kecman D., Vilotić D., Plančak M., Stefanović M. (2002) *Rivet heading – theoretical investigation and experimental verification*, Journal for Technology of Plasticity, Vol. 27, No1-2, pp 73-82
- [7] Vilotić D., Plančak M., Čupković Đ., Mandić V., Stefanović M. (2003) *FEM analysis of upsetting process by cylindrical dies with experimental verification*, Journal for Technology of Plasticity, Vol. 28, No 1-2, pp 83-98
- [8] Vilotić D., Plančak M., (2011) *Experimental tooling for contact stress measurement in bulk metal forming processes*, Journal for Technologies of Plasticity, Vol 36, No 1, pp 9-16
- [9] Kačmarčik I., Movrin D., Ivanišević A. (2011) *One contribution to the friction investigation in bulk metal forming*, Journal for Technologies of Plasticity, Vol 36, No 1, pp 35-48



## KONTAKTNI NAPONI I PROMENA SILE PRI SABIJANJU PRIZMATIČNOG UZORKA ALATIMA V-OBLIKA

*Ivanišević Aljoša, Vilotić Dragiša, Plančak Miroslav, Kačmarčik Igor, Movrin Dejan,  
Milutinović Mladimir, Skakun Plavka  
Faculty of Technical Science – University of Novi Sad, Serbia*

*Proces slobodnog sabijanja predstavlja osnovnu operaciju koja se često integriše u kompleksne tehnološke procese hladnog i toplog zapreminskog deformisanja metala. Ovaj proces takođe ima značajnu ulogu u analizi deformabilnosti materijala. Iz tih razloga bitno je poznavati naponsko-deformaciono stanje i glavne parametre procesa. Najčešće korištene metode za određivanje naponsko-deformacionog stanja su teorijske, eksperimentalne i numeričke metode.*

*U ovom radu je izvršena teorijska i eksperimentalna analiza procesa sabijanja prizmatičnog uzorka materijala Č 1531 alatima V oblika. Komponenta napona je određivana metodom rešavanja približne jednačine ravnoteže (metoda ravnih preseka), dok je sila deformisanja određena integracijom kontaktnih napona.*

*Poređenjem teorijskog rešenja i eksperimentalnih podataka može se zaključiti da je sila ostvarena u eksperimentu niža od sile dobijene teorijski. Vrednost normalnog napona veća je za uzorke manjih početnih dimenzija (serija PS) pri istom hodu alata zbog viših vrednosti efektivne deformacije i efektivnog napona. Za obe serije uzoraka vrednost napona opada sa povećanjem  $x$  koordinate.*

***Ključne reči:*** slobodno sabijanje, alati V- oblika, teoretska analiza, eksperiment