

DEFINING OF VARIABLE BLANK-HOLDING FORCE IN DEEP DRAWING

*Aleksandrović S., Stefanović M.
Faculty of Mechanical Engineering, Kragujevac, Yugoslavia*

ABSTRACT

Holding force is a significant parameter, which can be modified in course of deep drawing process. Variable blank-holding force makes possible the influence on the course and final results of the process.

The paper gives the original procedure for determining one type of variable blank-holding force dependence (so-called combined dependence) and a part of experimental results of its application on carbody steel sheet metal. The experiment was performed on a special laboratory computer device, which makes possible both the measurement of significant process parameters and control of variable blank-holding force. Parallel survey with results for constant blank-holding force defined in a classical manner, through empiric formulas, is given here. Qualitative indicators are observed (drawing depth, work piece properties, strain distributions, drawing force, influence on limit formability).

1. INTRODUCTION

It is typical that the intensity of holding force (F_D) in deep drawing of thin sheet metals has constant value during the process. This value is commonly determined through various empiric formulas and suggestions, whereat the specific holder pressure (q) is adopted [1]. By multiplying to the initial surface of contact, constant blank-holding force is obtained. In modern industry of plastic sheet metal forming new techniques are being introduced and there is a strong tendency to more complete control of deep drawing process and its results. Holding force has a convenient property - it can be simultaneously changed during the process (only draw beads of variable height have that quality) [2,3,4]. Therefore it is significant as a controlling element. Such an approach is completely justified, first of all because of application of new generation materials, which are of considerably worse formability than classical low-carbon sheet metals (Al-alloys and stainless steel sheet metals, high strength steel sheet metals, so-called tailored sheet metals etc). Also,

modern large-series industry (especially in car industry) demands the mastering of forming process to a larger extent, because it is impossible to perform manually some frequent smaller or bigger corrections during the production.

From previously given reasons, during the last decade, the possibilities of variable blank-holding force (VBF) influence have been investigated intensively [2,3,4]. The basic question is - which dependence of holding force on punch travel (or time) brings to favourable effects on course and results of process. There are no generally accepted premises in spite of significant results of comprehensive experimental researches, with the application of, often, very complex systems for measurement and control [3,4]. In thorough investigation [1,5] a method of VBF defining was suggested and it will be given here briefly.

In the context of tribological manifestations on flange, holding force represents the normal force for realized friction, and the mechanism of its process develops exactly in that way.

The details about friction on flange in the conditions of constant blank-holding force are given in many papers, for example [6,7].

2. DEFINING OF VARIABLE BLANK-HOLDING FORCE

A successful result of the process can be disturbed by two most important defects: the appearance of wrinkles on flange and the appearance of a crack in critical zone (fracture). The suggested functional dependence of holding force on travel (fig.1) was called combined due to its fall-rise character. It was formed with following aims:

- to prevent the appearance of wrinkles by sufficiently large intensity in the first phase,
- to achieve, in a certain sense, unloading on holder, considering the drawing force, during the process,
- to compensate for the appearance of wrinkles and tendency to sheet metal thickness increase by sufficient intensity in the last phase.

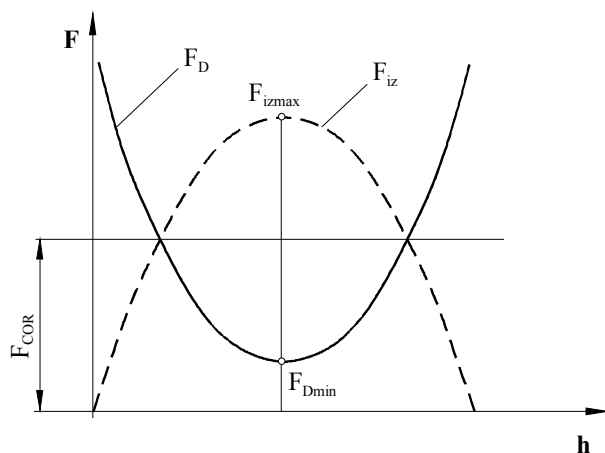

Fig. 1 Defining principle of combined blank holding force

In the periods of process where the drawing force increases, F_D should decrease, and vice versa. Maximum of drawing force should be followed by the minimum of holding force.

Considering the previous aims there was the idea of obtaining the holding force function on the basis of functional dependence of drawing force on the principle of symmetrical copying around conveniently chosen horizontal axis of symmetry (fig.1). The position of that line was determined by constant intensity of correction force F_{COR} , which is obtained on condition that the ordinate of curve F_D minimum is above minimal intensity of holding

force; that minimal intensity is determined empirically from the limit diagram of the drawing depth dependence on holding force ($h-F_D$), considering the appearance of wrinkles. Abscissa of the minimum point should correspond to the abscissa to the curve maximum of the drawing force obtained experimentally for actual work piece.

Therefore, in order to obtain the desired combined dependence of VBF, it is necessary to make the limit diagram $h-F_D$ and record the drawing force dependence on the punch travel (that is easiest to be done by constant blank-holding force). After that, the function of combined VBF is analytically defined. In certain cases the experimental part can be left out.

In order to come to the functional dependence of VBF, the function of drawing force dependence on punch travel or other convenient parameter (time, for example) should be determined. The next analysis was done for a cylindrical piece on the basis of classical theory [1] with certain corrections. The approach is empirically analytical and is applicable on prismatic pieces of square section as well.

Drawing force can be represented as:

$$F_{IZ} = A \cdot \sigma_{uiz} \quad (1)$$

where $A \approx d \cdot \pi \cdot s$ is the surface of the supporting square section, and a σ_{uiz} the total stress of deep drawing which can be defined through a well-known equation:

$$\sigma_{uiz} = (\sigma_r + \sigma_{trd}) k_\mu + \sigma_{savis} \quad (2)$$

σ_r is a component which refers to radial tensional stress on flange. σ_{trd} is a component due to friction on flange, caused by holding force. k_μ is a factor, which takes into consideration the friction on the rounding of the die opening edge. σ_{savis} is stress due to bending and straightening at sheet metal sliding across the die radius. Taking into consideration the previous equation, it is convenient to divide the total drawing force into particular components:

$$F_{IZ} = F_{OBL} + F_{TRD} + F_{TRM} + F_{SAVIS} \quad (3)$$

Forming force, which refers to flange forming (corresponds to stress σ_r) is:

$$F_{OBL} = A \cdot 1,15 \cdot \bar{K} \cdot \ln \frac{d}{D_0} \quad (4)$$

$$\sigma_r = 1,15 \cdot \bar{K} \cdot \ln \frac{\rho}{m} \quad (5)$$

Constants which define piece geometry are: piece diameter d , piece radius $r=r_u=d/2$, diameter and radius of blank D_0 and R_0 , drawing coefficient $m=r/R_0=d/D_0$. Independent variable (argument) is relative flange reduction: $\rho = R/R_0=D/D_0$. R and D are current values of flange diameter and radius. At the beginning of process $\rho = 1$, and at the end $\rho = m$. \bar{K} is the medium value of equivalent stress. It can be represented in the function of medium natural strain $\bar{\varphi}$.

$$\bar{\varphi} = \frac{1}{2} (\varphi_{iM} + \varphi_{iO}) \quad (6)$$

φ_{i0} is strain on flange edge:

$$\varphi_{iO} = \ln \frac{R_0}{R} = \ln \frac{l}{\rho} \quad (7)$$

Strain on die edge φ_{iM} is:

$$\varphi_{iM} = \ln \frac{\sqrt{l+m^2-\rho^2}}{m} \quad (8)$$

On the basis of the previous three equations it follows that:

$$\bar{\varphi} = 0,5 \cdot \ln \frac{\sqrt{l+m^2-\rho^2}}{m \cdot \rho} \quad (9)$$

Function $K=K(\varphi)$ is most convenient to be represented in linear form. That is the only way for the final drawing force curve to approach to the experimentally obtained curve by its shape. After a number of trials, the following dependence was obtained:

$$\bar{K} = c \cdot \bar{\varphi} ; c = \frac{R_M}{\varphi_M} \quad (10)$$

R_M is tensional strength, and φ_M is maximal homogenous natural strain in the trial of uniaxial tension (it is equal to „n” factor).

When equations (9) and (10) are included into the equation (5), the following equation is obtained:

$$\sigma_r = 0,575 \cdot \frac{R_M}{\varphi_M} \ln \frac{\sqrt{l+m^2-\rho^2}}{m \cdot \rho} \ln \frac{\rho}{m} \quad (11)$$

Friction force on flange, considering the contact on both sides of the flange, is:

$$F_{TRD} = 2 \cdot \mu \cdot F_D \quad (12)$$

The corresponding stress is:

$$\sigma_{trd} = \frac{2\mu F_D}{d\pi s} \quad (13)$$

Friction factor k_μ , in the equation (2) has the following value:

$$k_\mu = e^{\frac{\mu\pi}{2}} \quad (14)$$

Friction force on die radius can be represented as:

$$F_{TRM} = (F_{OBL} + F_{TRD}) \left(e^{\frac{\mu\pi}{2}} - 1 \right) \quad (15)$$

Force of sheet metal bending and straightening around die radius and its corresponding stress are:

$$F_{SAVIS} = A \frac{R_M}{2 \frac{r_M}{s} + 1} \quad (16)$$

$$\sigma_{savis} = \frac{R_M}{2 \frac{r_M}{s} + 1} \quad (17)$$

In the previous equations r_M is die radius.

With regard to equations (1) to (17) and accepting that friction coefficients on holder and die radius are equal (which corresponds to reality), the following equation for drawing force is obtained:

$$F_{IZ} = d\pi s \left[\left(0,575 \frac{R_M}{\varphi_M} \ln \frac{\sqrt{1+m^2-\rho^2}}{m \cdot \rho} \ln \frac{\rho}{m} + \frac{2\mu F_D}{d\pi s} \right) e^{\frac{\mu\pi}{2}} + \frac{R_M}{2 \frac{r_M}{s} + 1} \right] \quad (18)$$

Besides geometrical constant parameters (d, s, m, r_M), material characteristics (R_M and φ_M), friction coefficient μ and holding force F_D appear in the equation as well. For force F_D a constant value is taken on the basis of empirical suggestions or from the limit diagram of wrinkles and fracture $h-F_D$ [1]. Fig.2 shows the satisfactory congruence of drawing force determined by equation (18) and the one obtained experimentally. For the purpose of experiment, relative lessening of flange should be connected to time. With the assumption about linear connection (fig.3), the following equation is obtained:

$$\rho = 1 - \frac{l-m}{T_{max}} t \quad (19)$$

Considering the principle given in fig.1 and equation (18), the function of combined VBF is finally obtained as:

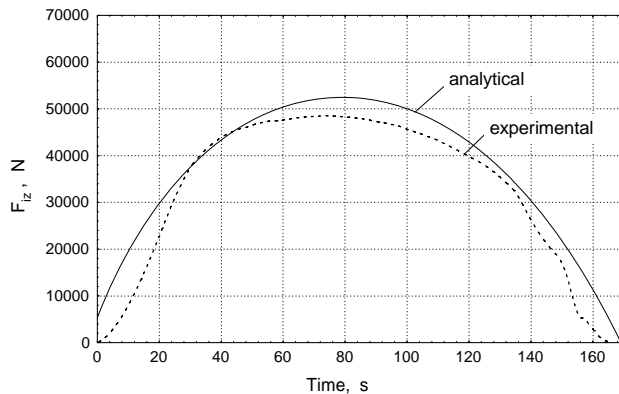

Fig. 2 Analytical and experimental drawing force

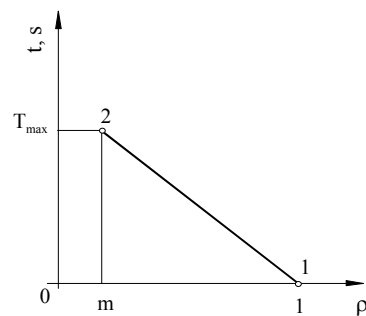

Fig. 3 Time to flange reduction relation

$$F_D = 2F_{COR} - F_{IZ} \quad (20)$$

The previous equations can be applied to prismatic pieces of square section as well, but instead of diameter d the equivalent diameter d_e is used. In other words, the size of punch square section is, pro-forma, reduced to the size of the circle.

3. THE RESULTS OF EXPERIMENTS

The experiments, a part of which is given in this paper, are performed on previously mentioned laboratory device, two basic parts of which are: hydraulic press for sheet metals investigation ERICHSEN 142/12 and computer system for measurement and control (fig.4). That is the triple action press with maximal measurement range of main action force 0-130 kN, holding force 0-32 kN and forming speed 0-200 mm/min. Maximal drawer diameter is 50 mm, and maximal drawing ratio is 2,4. In the original version, the machine was equipped with inductive force and travel transducers for main action, with manometers with Bourdon's tubes for all working actions. Continuous regulation of holding force can be done manually by hand regulated hydro-valve. For the purposes of these researches, modifications were carried out in the system for realization, measurement and control of holding force. Modifications include the following: first, built-in electromotor drive with DC motor and two connected reduction worm gears applied on hydraulic valve for holding force regulation, and second, built-in inductive transducer for holding force measurement. Control of electromotor drive was integrated into the computer system for

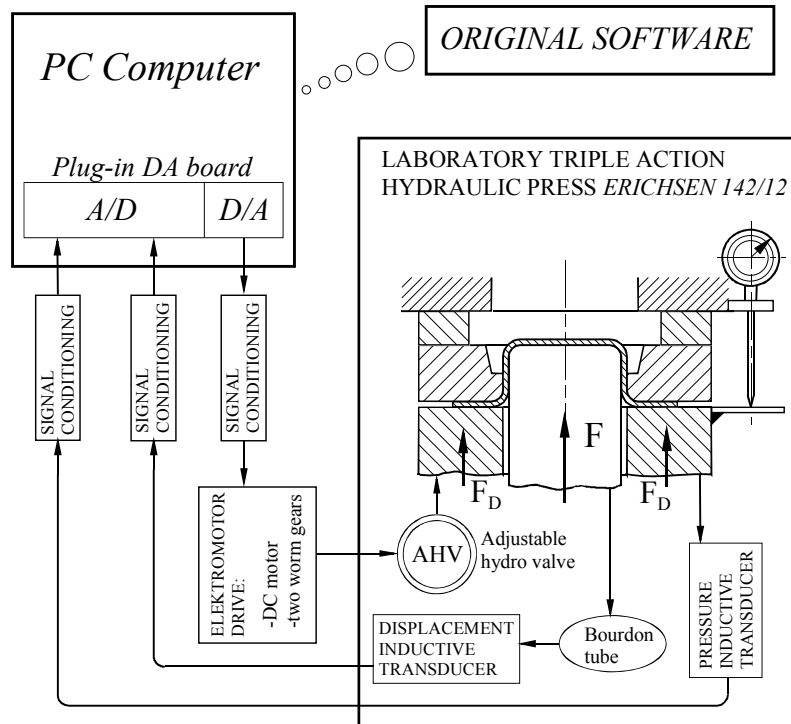

Fig. 4 Scheme of experimental equipment

measurement and control. Control of electromotor drive is performed in closed loop (by feedback principle) on the basis of given functional (or other) dependence of holding force and continually measured realized holding force. The central part of the acquisition system is PC computer with built-in 12-bit AD/DA card. On the basis of previously given and measured holding force intensity, valve axis position dependence on time during the process is defined, as well as variable blank-holding force. By switching DC electromotor drive in desired moments, with the use of specially developed electronic control unit, variable blank-holding force to programme defined intensity is obtained, and it is measured directly, by holding force transducer. The dependence of actually realized VBF is in the shape of steplike line, with deviation from the given one, which is adjusted by programme. The choice of arbitrary type of force dependence, either as analytically given functions or as a unit of discrete values, or combined, is provided through software. The developed software serves, as well, for other needs of experiment (drawing force measurement, visual control of process, memorizing of all required values, etc). System for measurements also makes possible the mechanical measuring of wrinkle height on flange with reading accuracy of 0,01 mm. Because of limited space, it is impossible to give more details about this system; they can be found in [1].

Here, we shall give a part of results obtained with application of combined holding force at drawing of a cylindrical work piece made of classical low-carbon steel carbody sheet metal 0,8 mm thick. Details about material properties are given in [1]. Work piece geometry was defined by its diameter $d=50$ mm and drawing ratio 2,2 (drawing coefficient $m=0,454$).

On one hand the constant blank-holding force (CBF) was defined on the basis of empirical suggestions in literature $F_D= 13,72$ kN [1], and on the other hand three dependencies of combined VBF according to the equations given in the previous chapter were defined. Each of the curves (fig. 5) refers to the one type of contact conditions (dry surfaces, oil application, and oil and foil application).

Realized effects are followed through: diagram of holding force dependence on travel, drawing depth with qualitative estimation about wrinkles and fracture on work piece, strain distributions in the coordinate system of main strains in sheet metal plane ($\varphi_1 - \varphi_2$) and thinning distribution in dependence on the position on work piece.

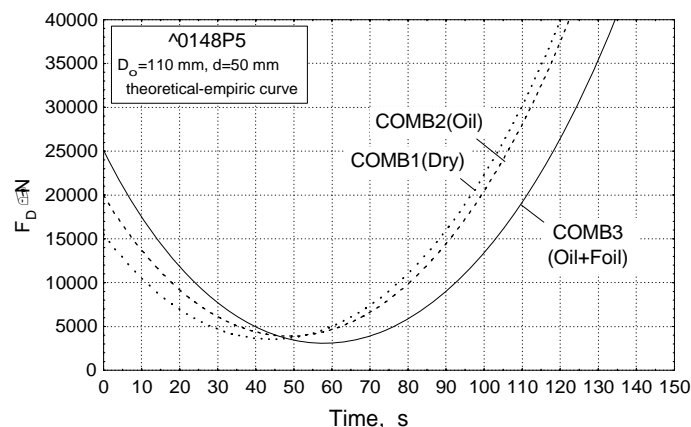

Fig. 5 Functions of combined VBF

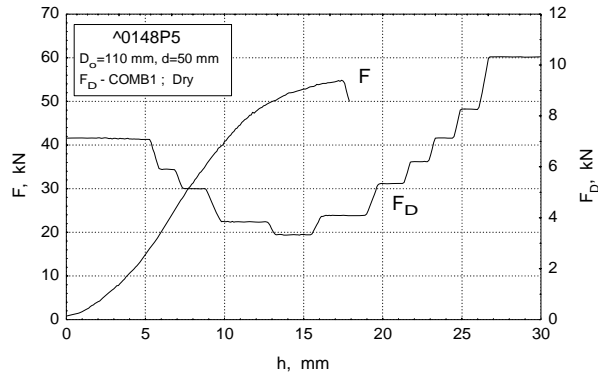

Fig. 6 Drawing force and VBF COMB1

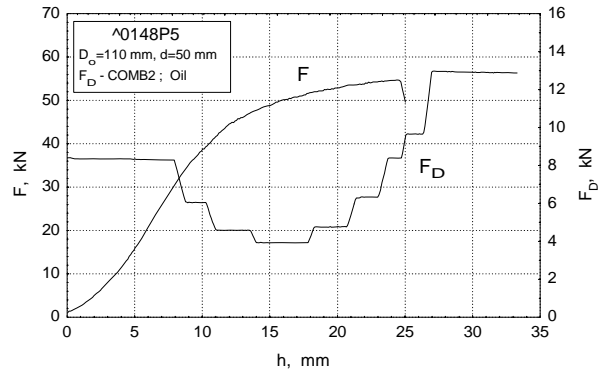

Fig. 7 Drawing force and VBF COMB2

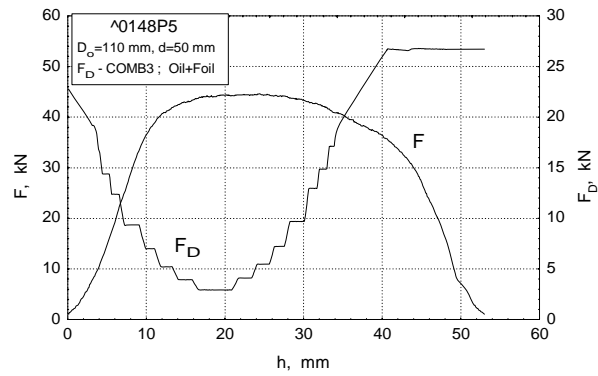

Fig. 8 Drawing force and VBF COMB3

Figures 6-8 show measured drawing force curves along with the realized holding forces. In the conditions of highly prominent friction (dry surfaces-D) with combined VBF COMB1, maximal drawing depth increases for 32,3% in comparison to estimated constant holding force. In the mixed friction regime (oil-O) depth increase is 10,8% (COMB2). By The application of holding force COMB3, full work piece depth is obtained, but starting with the depth of about 38 mm, small wrinkles which can be ironed during the process, can be observed.

Figure 9 shows strain distributions in the sheet metal plane. Influence of both holding force and friction are very prominent. In the case of dry surfaces, holding force COMB1 results in a more favourable distribution. The loop is wider, which reduced the thinning gradient, which is seen clearly in fig. 10. The consequence of that is a considerable increase of work piece depth. The decrease of friction reduces the influence of holding force. In the conditions of very small friction (oil and foil) there are practically no changes in distributions. The application of oil brings to small improvements with the application of force COMB2.

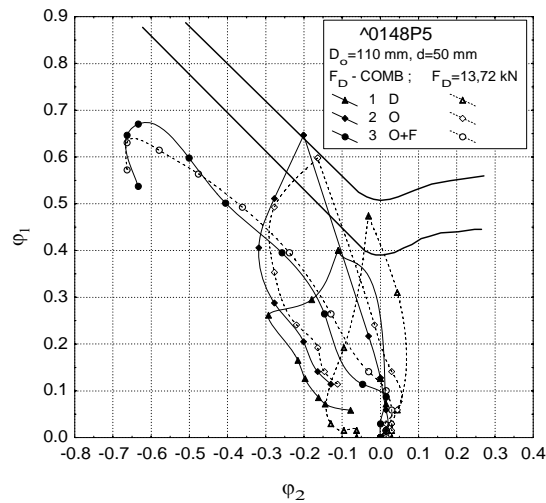
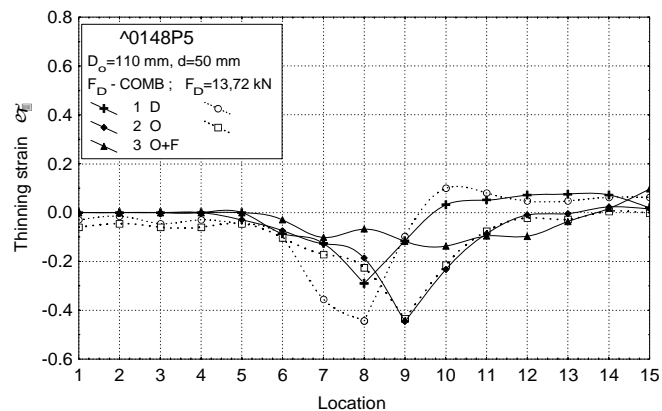

Fig. 9 Strain distributions in sheet plane



LITERATURE

- [1] Aleksandrović S. : Deep Drawing of Thin Sheet Metals at Nonmonotonous Forming with Variable Tribological Conditions, Ph.D.– thesis, Faculty of Mechanical Engineering , Kragujevac, 2000. (In serbian).
- [2] Wagner S.: Tribology in drawing car body parts, 11th International colloquium, Technische Academie Esslingen, Proc., Vol. III, pp. 2365–2372, 1998.
- [3] Siegert K. et al.: Closed–loop control system for blank holder forces in deep drawing, Annals of CIRP Vol. 44/1/1995., pp. 251–254.
- [4] Siegert K., Ziegler M., Wagner S. : Closed loop control of the friction force. Deep drawing process, Journal of Mater. Proc. Technol. 71 (1997), pp. 126–133.
- [5] Aleksandrović S., Stefanović M., Taranović D.: Variable contact conditions influence on formability of thin sheet metals by deep drawing, Journal for Techn. of Plasticity, Vol. 23, 1–2, pp. 31–41, Novi Sad, 1998.
- [6] Stefanović M.: Tribology of deep drawing, Yugoslav society for tribology and Faculty of Mechanical Engineering, Kragujevac, monograph, 1994. (In serbian).
- [7] Emmens W.: Tribology of Flat Contacts and its Application in Deep Drawing, Ph.D.–thesis, University Twente, Nederlands, 1997.

DEFINISANJE PROMENLJIVE SILE DRŽANJA PRI DUBOKOM IZVLAČENJU

*S. Aleksandrović, M. Stefanović
Mašinski fakultet, Kragujevac*

REZIME

Sila držanja je značajan parametar koga je moguće menjati simultano tokom trajanja procesa dubokog izvlačenja. Promenljiva sila držanja omogućava uticaj na tok, kao i na konačne rezultate procesa.

U radu se daje originalni postupak određivanja jednog tipa zavisnosti promenljive sile držanja (tzv. „kombinovana zavisnost“) i deo eksperimentalnih rezultata primene na karoserijskom niskougleničnom čeličnom limu. Eksperiment je realizovan na specijalnom laboratorijskom kompjuterskom uređaju koji, pored merenja značajnih parametara procesa, omogućava upravljanje silom držanja. Daje se uporedni prikaz rezultata u uslovima primene konstantne sile držanja (definisane na klasičan način preko empirijskih formula) sa rezultatima dobijenim pri korišćenju predložene „kombinovane zavisnosti“ promenljive sile držanja. Praćeni su kvalitativni pokazatelji (dubina izvlačenja, karakteristike komada), distribucije deformacija u ravni lima i deformacije stanjenja, sila izvlačenja, uticaji na graničnu deformabilnost.

Registrovana su značajna poboljšanja parametara procesa i karakteristika izvucenog komada.